

8 7 6 5 4 3 2 1

D
C
B
A

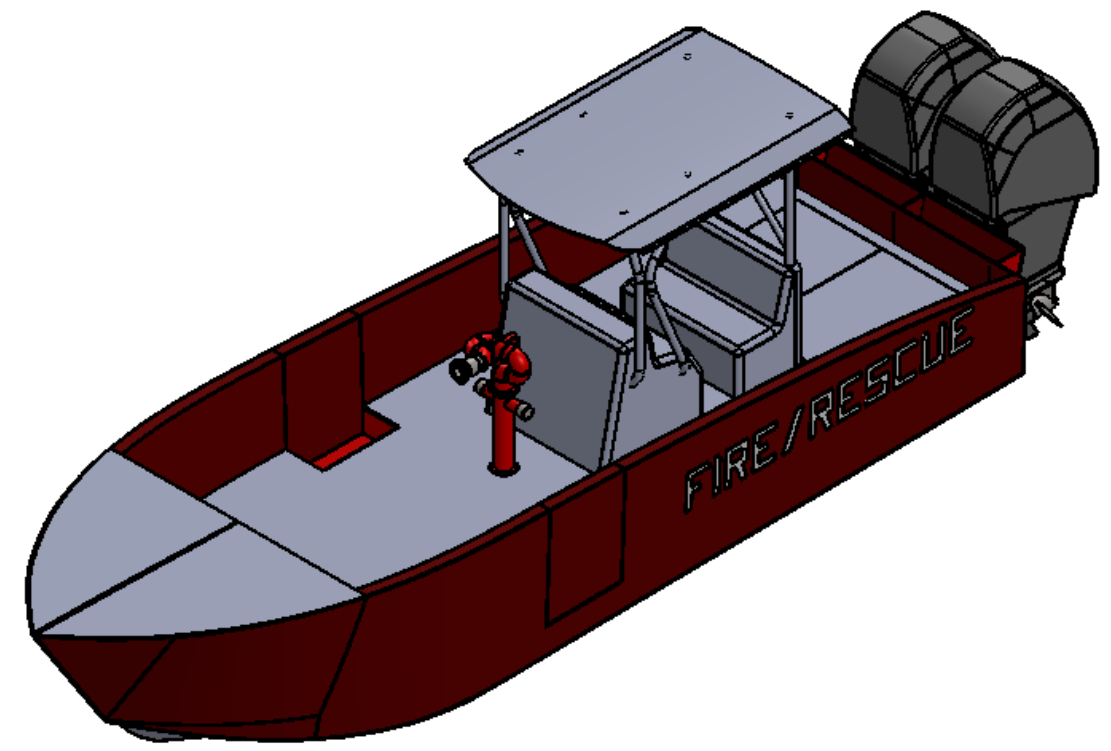
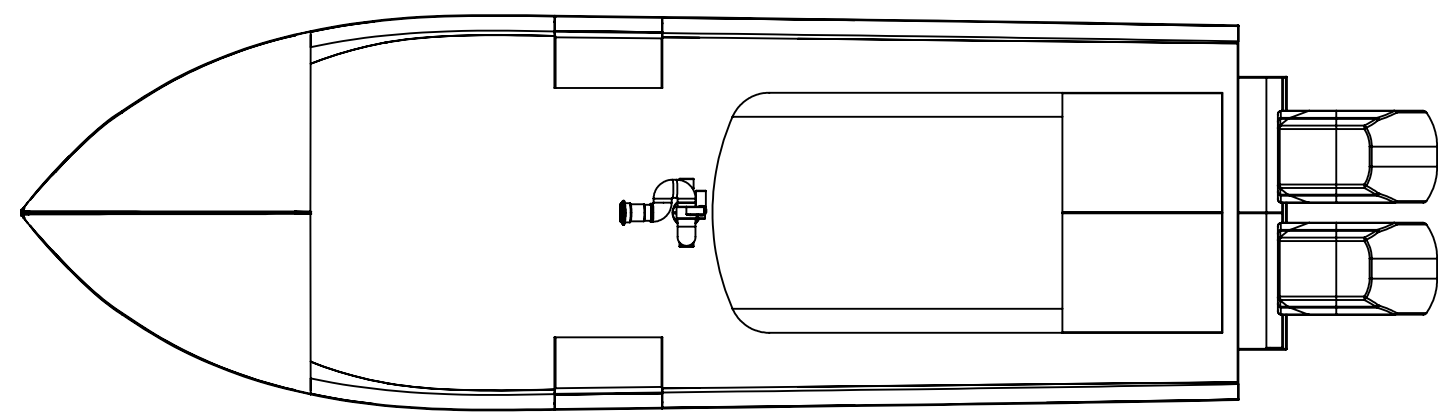
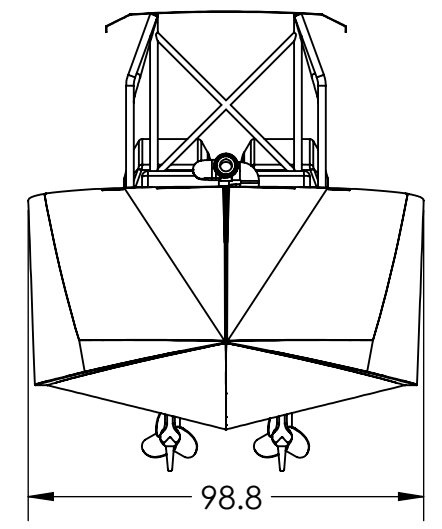
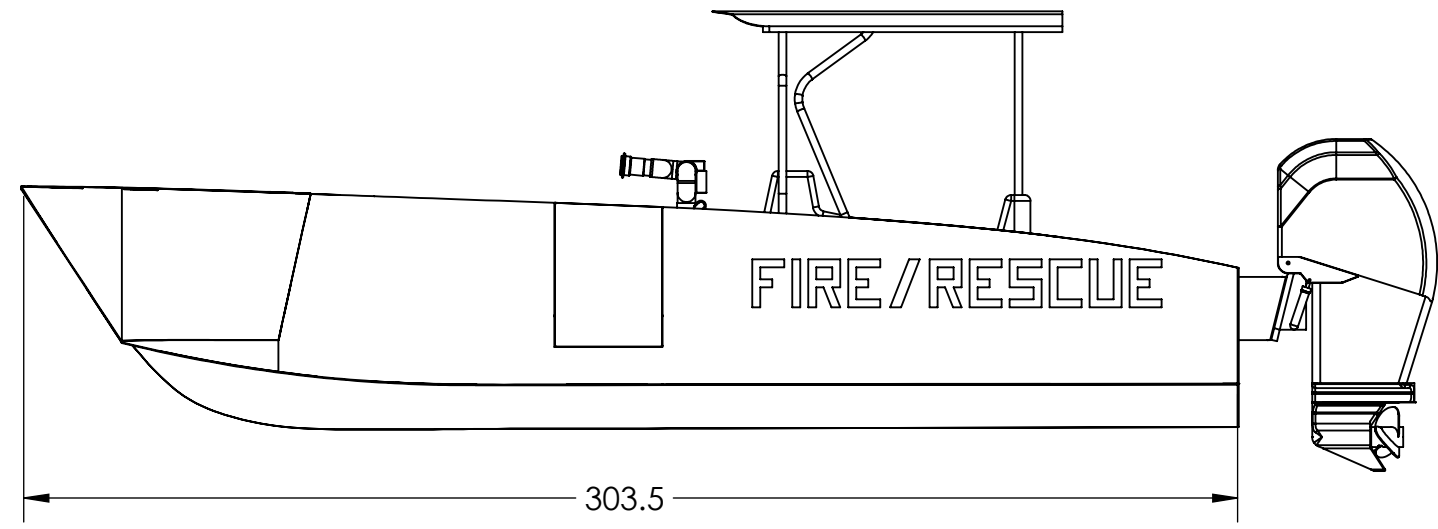
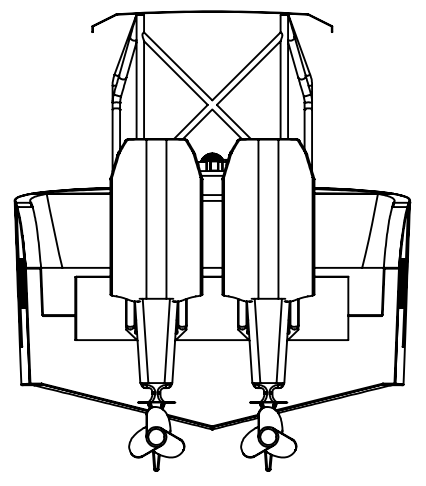

PROPRIETARY AND CONFIDENTIAL
THE INFORMATION CONTAINED IN THIS
DRAWING IS THE SOLE PROPERTY OF
HARBOR GUARD BOATS. ANY
REPRODUCTION IN PART OR AS A WHOLE
WITHOUT THE WRITTEN PERMISSION OF
HARBOR GUARD BOATS IS
PROHIBITED.

		UNLESS OTHERWISE SPECIFIED:		NAME	DATE	HARBOR GUARD BOATS		
		DIMENSIONS ARE IN INCHES TOLERANCES: FRACTIONAL $\pm 1/64$ ANGULAR: MACH $\pm .05$ BEND $\pm .25$ TWO PLACE DECIMAL $\pm .01$ THREE PLACE DECIMAL $\pm .003$		DRAWN	PDR			10/08/11
		INTERPRET GEOMETRIC TOLERANCING PER:		CHECKED		TITLE:		
		MATERIAL		ENG APPR.		SPLIT BOW 26		
		FINISH		MFG APPR.				
NEXT ASSY	USED ON	PART NUMBER:				SIZE	DWG. NO.	REV
APPLICATION		DO NOT SCALE DRAWING				B		A
						SCALE: 1:48 WEIGHT:		SHEET 1 OF 1

8 7 6 5 4 3 2 1